

Illustration, 30 inch Corn.
 Within 30 days of banding TAPPKTS bands are indexed to the side of planter seed row at 5 inch offset of the index.

Plant directly on top of the deep banding of TAPPKTS with 30 days or greater separation with the planter operations.

The bands are placed at 7 inches to 8 inches depth.

Acres per minute, 1.212 at 10 mph.
 1 acre per minute at 8.22 mph.

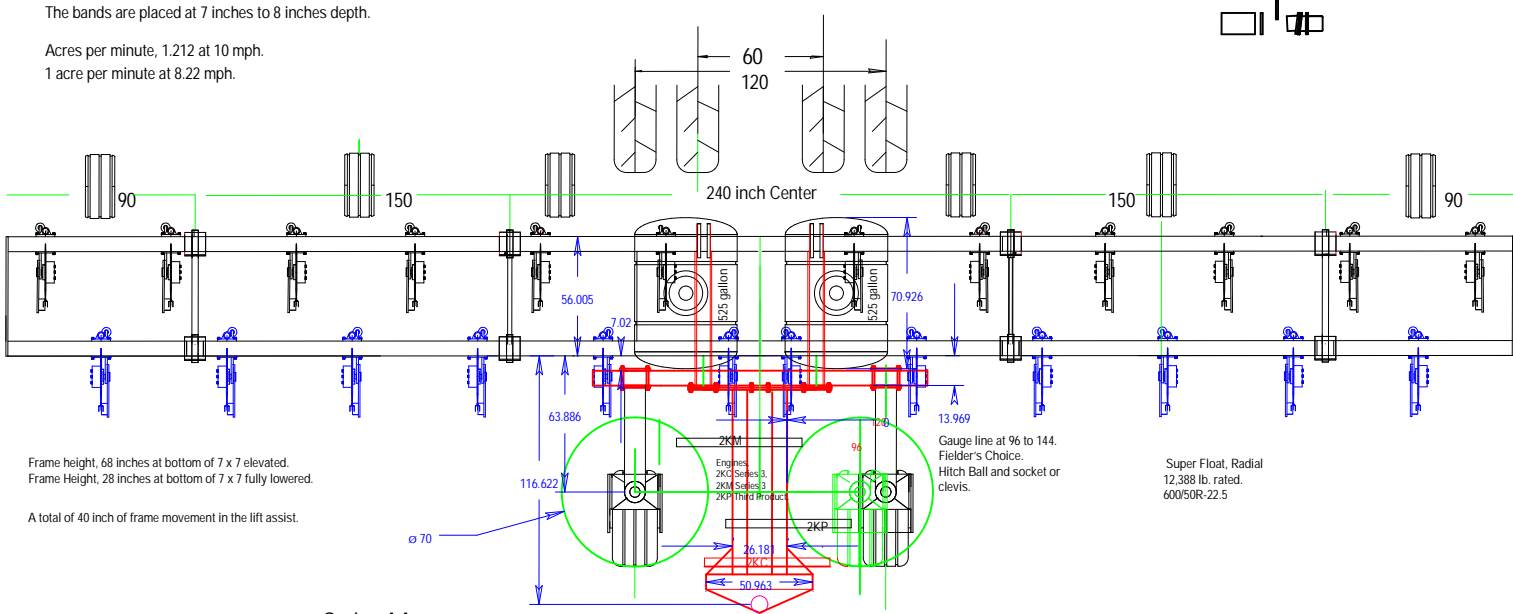

Series AA

Machine Width	Center Section Narrow	Transport width	Transport Height	Sections	Squat Height	Lift assist	Hitch Rating	Ballast Tanks	Max Tool Bar Height	Color	Weight	Bar 7 x 7	Lift Assist Tire	Pos. Down Pres	Band Spacing	Ground Speed	Tire Options	TC	Goodland
40 ft.	6 row, 180	19 ft. 4 inch	16 ft. 3 inch	3	15 ft. 2 inch	18,000 lbs.	35,000 lbs.	125 to 400 ea.	64 inches bottom	Any	24,570	375 wall	19.1 x 19.7 600 lbs.	Yes	10, 12, 15, 20	10 to 12 mph			
55 ft.	6 row, 180	19 ft. 4 inch	16 ft. 3 inch	5	15 ft. 2 inch	18,000 lbs.	35,000 lbs.	125 to 400 ea.	64 inches bottom	Any	31,125	375 wall	19.1 x 19.7 600 lbs.	Yes	10, 12, 15, 20	10 to 12 mph			
40 ft.	8 row, 240	22 ft. 4 inch	12 ft. 4 inch	3	11 ft. 3 inch	18,000 lbs.	35,000 lbs.	125 to 400 ea.	64 inches bottom	Any	33,125	5 wall Center	21.5L x 16.1SL 8,800 lbs.	Yes	10, 12, 15, 20, 30	10 to 12 mph			
45 ft.	8 row, 240	22 ft. 4 inch	14 ft. 10 inch	3	13 ft. 9 inch	18,000 lbs.	35,000 lbs.	125 to 400 ea.	64 inches bottom	Any	33,125	5 wall Center	21.5L x 16.1SL 8,800 lbs.	Yes	10, 12, 15, 20, 30	10 to 12 mph			
48 ft.	8 row, 240	22 ft. 4 inch	15 ft. 10 inch	3	14 ft. 8 inch	18,000 lbs.	35,000 lbs.	125 to 400 ea.	64 inches bottom	Any	38,125	5 wall Center	21.5L x 16.1SL 8,800 lbs.	Yes	10, 12, 15, 20	10 to 12 mph			
60 ft.	8 row, 240	24 ft.	16 ft. 3 inch	5	15 ft. 2 inch	25,000 lbs.	80,000 lbs.	125 to 400 ea.	64 inches bottom	Any	59,425	5 wall Center	Super Float, Radial 12,388 lb. rated 60050R-22.5	Yes	12, 15, 20, 24, 30	10 to 12 mph			
63 ft.	8 row, 240	24 ft.	16 ft. 3 inch	5	15 ft. 2 inch	25,000 lbs.	80,000 lbs.	125 to 400 ea.	64 inches bottom	Any	43,125	5 wall Center	Super Float, Radial 12,388 lb. rated 60050R-22.5	Yes	12, 15, 20, 24	10 to 12 mph			
68 ft.	8 row, 240	24 ft.	16 ft. 3 inch	5	15 ft. 2 inch	25,000 lbs.	80,000 lbs.	125 to 400 ea.	64 inches bottom	Any	48,125	5 wall Center	Super Float, Radial 12,388 lb. rated 60050R-22.5	Yes	12, 15, 20, 24	10 to 12 mph			

48 x 15 inch rows.

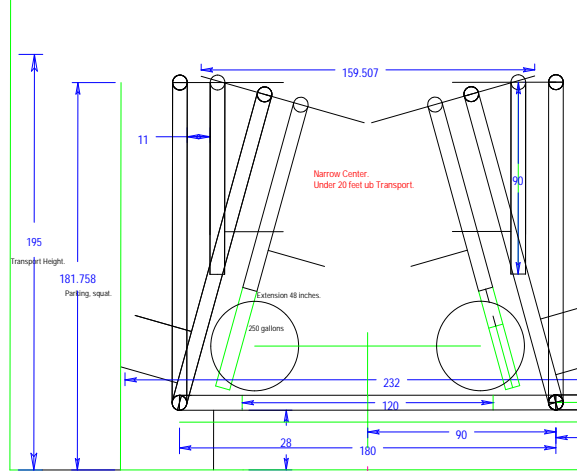

Mustang Yelder, 6015, 5 section with tanks and lift assist.
 Goodland Tool Bar, 5 sections, Positive down pressure, \$157,120
 Mustang P-51CE 3/8 x 25 inch, replaceable bit, press in TIO, \$48
 2KC Series 3, 2KM Series 3, 2KP, 2KR Blender Looking Glass \$167,127
 4 section, Dual product design.
 Mass Flowmeter Readouts Cab Mounted.
 Total Assembled FOB, Shelton, NE, \$556,254.
 FOB Spokane,
 John Cory 10% down, 5 payments. Security West. John will quote today.
 Finance with Dechant the Banker, 90% down with order, 10% at delivery.

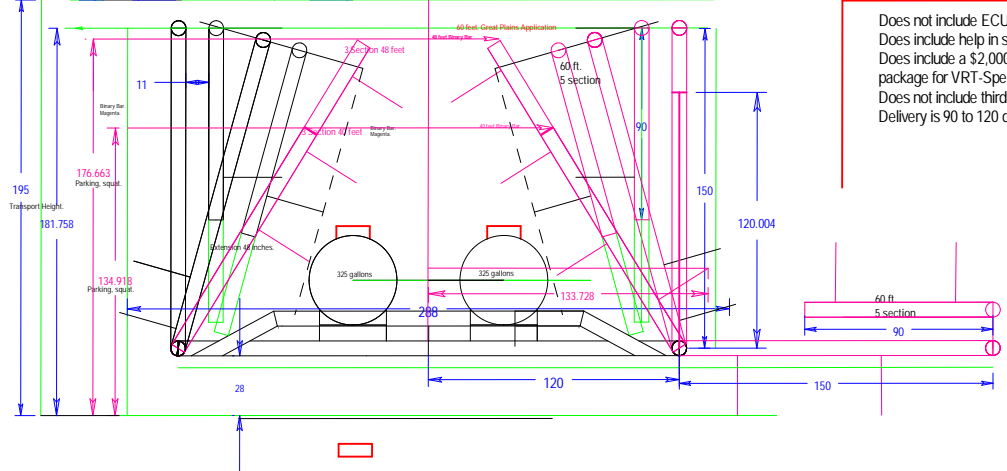

Does not include ECU's from Deere.
 Does include help in set up.
 Does include a \$2,000 entire farm Sat Shot package for VRT-Specific.
 Does not include third product, tank.
 Delivery is 90 to 120 days.